

**Code: 00 6R00002**  
**F1/221 - 400V 50Hz - 1.5HP 2P**

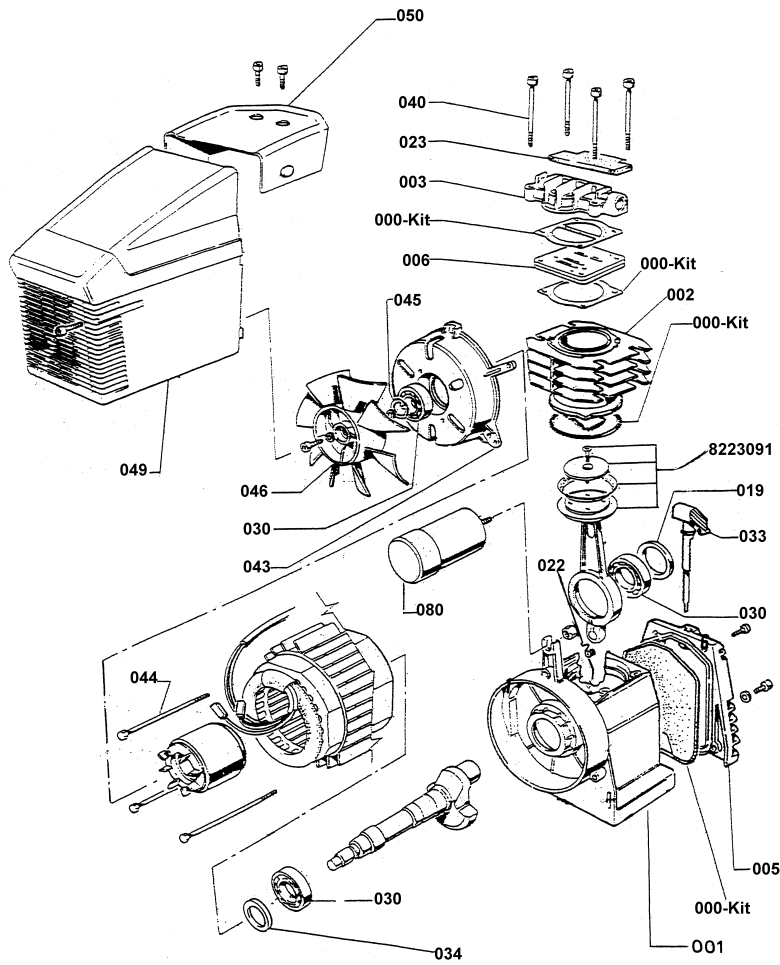

**Dimensions:**

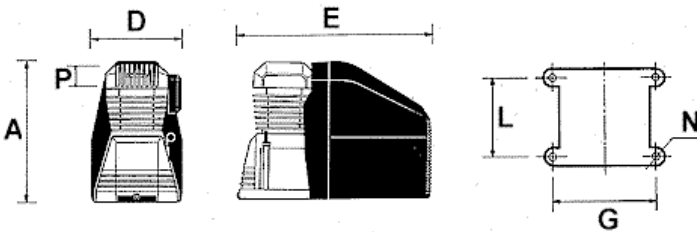

In mm

A	B	C	D	E	F	G	L	M	N	P
270	/	/	165	375	/	139	64	/	9	3/8" F

Box Weight:  Kg    Box Dimensions: W x D x L:  x  x

**Tightening Torques, Cylinder Head:**

Bolt Size:	<input type="text" value="M6"/>
Min Torque:	<input type="text" value="9.3"/> Nm
Max Torque:	<input type="text" value="11.36"/> Nm

**Technical Data:**

Cylinders:	<input type="text" value="1"/>	
Stages:	<input type="text" value="1"/>	
Air Flow:	<input type="text" value="220"/> L/min	<input type="text" value="7.8"/> cfm
Power:	<input type="text" value="1.1"/> Kw	<input type="text" value="1.5"/> HP
Speed:	<input type="text" value="2850"/> rpm	
Max Pressure:	<input type="text" value="8"/> Bar	<input type="text" value="116"/> psi

**Code: 00 6R00002**  
**F1/221 - 400V 50Hz - 1.5HP 2P**



<i>Svc</i>	<i>Ref</i>	<i>Code</i>	<i>Description</i>	<i>Qty</i>	<i>Modified</i>
<input checked="" type="checkbox"/>	000	00 6R50050	Gasket Kit	1	
<input type="checkbox"/>	001	00 7161100	Crankase	1	
<input type="checkbox"/>	002	00 6P30000	Cylinder	1	
<input type="checkbox"/>	003	00 7161400	Pump head	1	
<input type="checkbox"/>	005	00 7161300	Crankase gasket	1	
<input checked="" type="checkbox"/>	006	00 0540051	Valve plate assy.	1	
<input type="checkbox"/>	022	00 9014009	Oil dipper	1	
<input checked="" type="checkbox"/>	023	00 7181100	Filter	1	
<input type="checkbox"/>	030	00 9170030	Bearing	1	
<input type="checkbox"/>	030	00 9170060	Bearing	1	
<input type="checkbox"/>	030	00 9170091	Bearing	1	
<input type="checkbox"/>	033	00 9024015	Oil fill plug	1	
<input type="checkbox"/>	034	00 9163010	Oil seal	1	
<input type="checkbox"/>	040	00 9011043	Cylinder head bolts	4	
<input type="checkbox"/>	043	00 6562203	Motor cover	1	
<input type="checkbox"/>	044	00 9011040	Motor bolts	3	
<input type="checkbox"/>	045	00 9140160	Circlip	1	
<input type="checkbox"/>	045	00 9140170	Circlip	1	
<input type="checkbox"/>	046	00 9038017	Fan	1	
<input type="checkbox"/>	049	00 830190A	Cover	1	
<input type="checkbox"/>	050	00 830150A	Cover plate	1	

*Svc = Service Item*